

# TIGERGRIP / TG 22-50

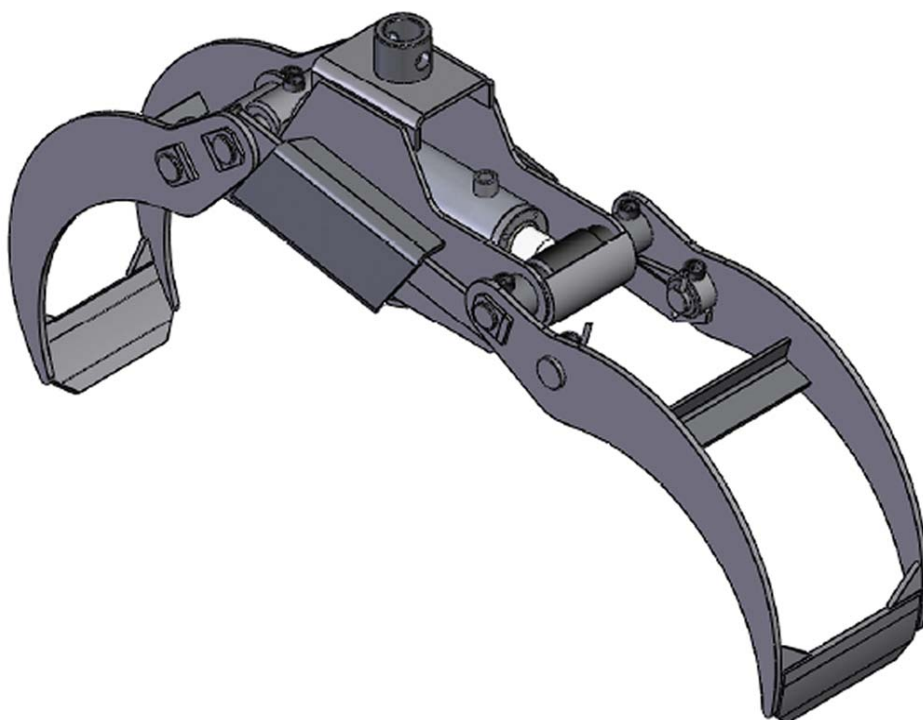

## Caractéristiques :

- Doubles barres de guidage.
- Capacité à enrouler et dérouler le bois optimisée.
- Vérin haute pression avec double joint de piston.

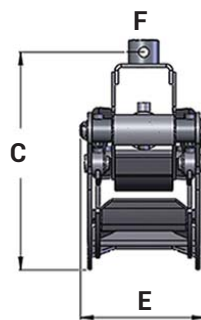
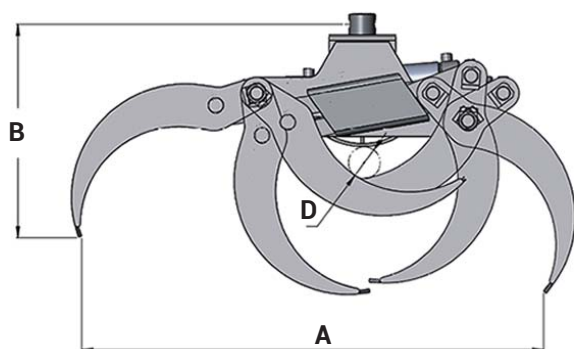

<b>A</b>	1310
<b>B</b>	606
<b>C</b>	544
<b>D</b>	90
<b>E</b>	311
<b>F</b>	50/25

## CARACTERISTIQUES



TG 22-50

98

0,22

200

50

13,5

3

1,5

# INTERMERCATO

Accessoires de levage et de chargement de haute performance pour le forestier, le transport, le TP et le recyclage.

